

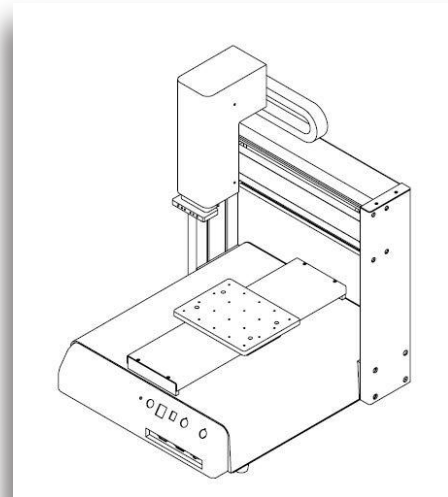

Product Description

- Available in four sizes
- Stage designed to securely mount plasma heads
- Accurately controls scan speed and source-to-sample distance



North America – Headquarters

2631 Manhattan Beach Blvd
Redondo Beach, CA 90278
Ph: +1 (310) 558-0770
sales@surfxtechnologies.com

Europe

Ph: +49 813 4557 0012 (Germany)
alex.wanninger@novel-tec.de

Asia Pacific Region

Ph: +886 4 2263 8200 (Taiwan)
salesasia@surfxtechnologies.com

Technical Specifications

Item	RB200-XYZ	RB300-XYZ	RB400-XYZ	RB500-XYZ
Working Range X/Y/Z (mm)	200 / 200 / 50	300 / 300 / 100	400 / 400 / 100	500 / 500 / 100
Load Y-axis / Z-axis	5kg / 3kg	10kg / 5kg		
X & Y / Z (mm/sec)	0.1~500 / 300	0.1~600 / 300		
Resolution	0.001 mm / Axis			
Program Capacity	100 set 4000 points / set			
Program Display	Teach Pendant LCD			
Control Method	PTP & CP			
Interpolation Function	3 Axis 3D route			
Programming Method	Teaching Pendant			
I/O Signals Port	8 Inputs / 8 Outputs			
External Control Interface	R232			
Power Supply	AC110~220V 300W			
Dimensions (WxDxH mm)	380 x 370 x 500	485 x 500 x 600	585 x 600 x 600	690 x 710 x 600s
Weight	23kg	30kg	40kg	45kg